

Trophy Truck Brake System



Alcon is one of the world's foremost manufacturers of brake systems for motor sport. For over 20 years, winning race teams have relied on Alcon to deliver the best brake technology for applications including World Rally, IndyCar, Formula 1 and NASCAR.

Alcon has now applied its expertise and experience to developing a complete brake system for the unique demands off road racing—resulting in a world class brake system that sets a new standard for brake performance in Trophy Trucks.

Features & Benefits

- 6 piston monoblock caliper machined from high strength alloy billet, with integral bridge provides the stiffest caliper body reducing flex in the system.
- Radial mounting reduces caliper deflection.
- Internal fluid passageways eliminate vulnerable external bridge pipes and fittings.
- Bleed-screws protected by screw-on caps.
- Wiper seals prevent dirt entering piston bores.
- Stainless steel pistons for maximum durability.
- Staggered piston sizes eliminate pad taper.
- Large piston area for maximum clamping force.
- Large pad volume for maximum pad life.
- 48 curved vane rotors with unique turbulators for enhanced cooling.
- Hard anodized billet aluminum bells available.

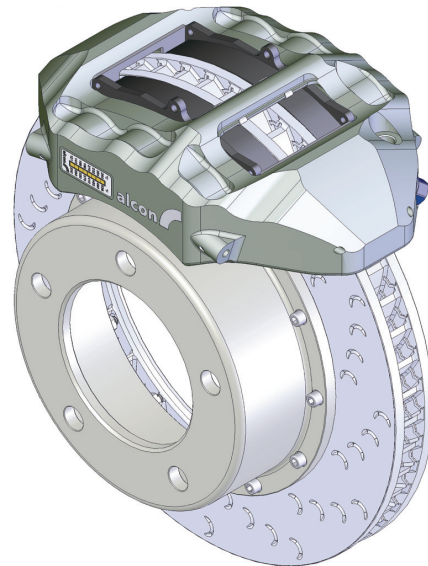

Specifications

<u>Large Piston Diameter</u>	<u>1.75" (44.5mm)</u>
<u>Middle Piston Diameter</u>	<u>1.50" (38.1mm)</u>
<u>Small Piston Diameter</u>	<u>1.31" (33.3mm)</u>
<u>Pad Thickness</u>	<u>1.12" (28.6mm)</u>
<u>Rotor Diameter</u>	<u>14.0" (355mm)</u>
<u>Rotor Thickness</u>	<u>1.40" (35.5mm)</u>

Installation drawing on reverse

Alcon USA

T (847) 788-0901

E info@alconusa.com

www.alconusa.com

